

## FluoroGrip® Fluoropolymer Pipe Wrap

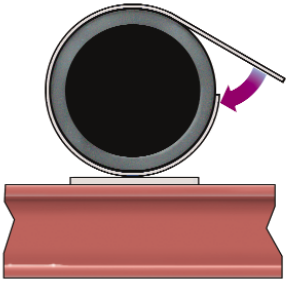

### An easy-to-install protective system for pipe and pipe support applications

FluoroGrip® Fluoropolymer Pipe Wrap offers easy-to-install mechanical protection to help prevent damage such as scrapes and corrosion caused by pipe expansion and contraction.

Providing excellent resistance to chemicals, abrasion, and other aggressive conditions, FluoroGrip Pipe Wrap provides protection in numerous applications in chemical plants, utilities and other industries.

### FluoroGrip Pipe Wrap advantages include:

- See-through film allows easy inspection of underlying paint or coating condition on pipe
- Simple to install – slides easily under pipe
- Low friction – fluoropolymer base minimizes surface wear caused by movement of pipe
- Prevents UV degradation of FRP reinforced and thermoplastic piping
- Remains effective over expanding and contracting substrates due to superior mechanical properties
- Fluoropolymer composition for high temperature resistance
- Superior chemical resistance
- High reliability in the widest range of environments
- Reduced labor and installation costs
- Reduced downtime costs

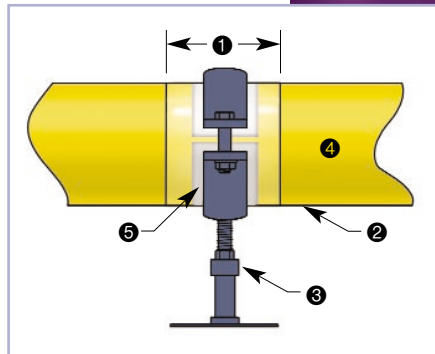

### Bolt-On Split Pipe Shoe Support

See-through FluoroGrip film provides protection between the bolt-on shoe support and the pipe. The film allows inspectors to easily verify the integrity of the underlying protective coating at each shoe location with a quick visual inspection.

FluoroGrip offers easy, peel-and-stick installation and superior reliability compared to other, more difficult to apply, opaque coatings and linings such as FRP.

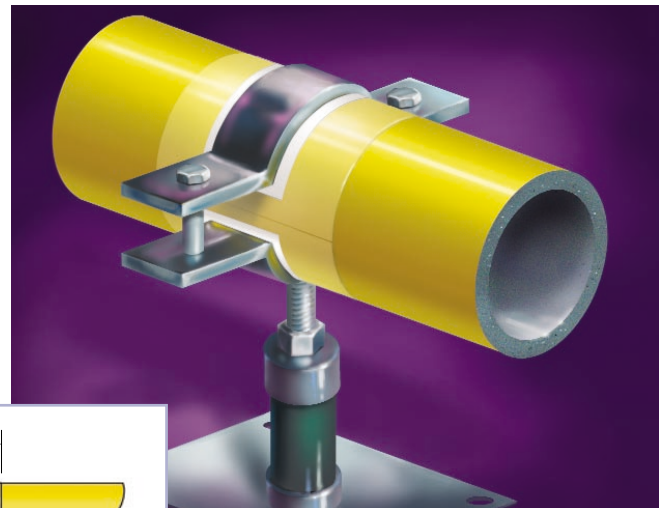

- 1 6" wide, 10-20 mil **FluoroGrip E** (ECTFE) high temperature, pressure sensitive, adhesive-backed film, clear
- 2 X" O.D. Pipe, uninsulated
- 3 Bolt-On, split pipe shoe on X" Foot Centers
- 4 Pipe coated with traditional protective coating systems
- 5 **FluoroGrip P** (PTFE) Shoe clamp pad

## Integument

Integument Technologies, Inc.

70 Pearce Avenue, Tonawanda, NY 14150  
 Phone: (716) 873-1199 • Fax: (716) 873-1303  
 e-mail: [info@integument.com](mailto:info@integument.com)  
[www.integument.com](http://www.integument.com)

# FluoroGrip® Fluoropolymer Pipe Wrap

## Pipe Slide Plate Applications

See-through FluoroGrip® film provides similar protection in slide plate applications as shown in the illustration.

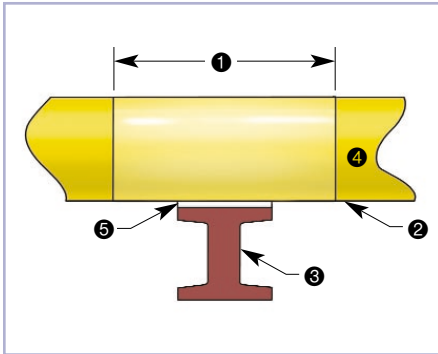

- ❶ 8" wide, 10-20 mil **FluoroGrip E** (ECTFE) high temperature, pressure sensitive, adhesive-backed film, clear
- ❷ X" O.D. pipe
- ❸ Support "I"-Beam
- ❹ Pipe and beam coated with traditional protective coating systems
- ❺ **FluoroGrip P** (PTFE) Friction pad

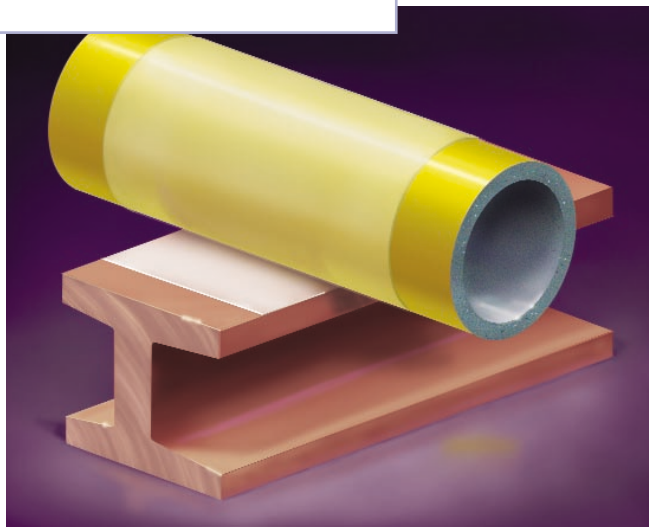

## Pipe Decal Protection

See-through FluoroGrip film protects pipe decals such as required safety warnings and related graphics while maintaining readability.



## High Temperature Corrosion Protection Under Insulation

High temperature resistant FluoroGrip film (to 450°F) combines superior protection and ease of installation under insulation and over new field welds. Ideal for protecting weld joints on metallized pipe.

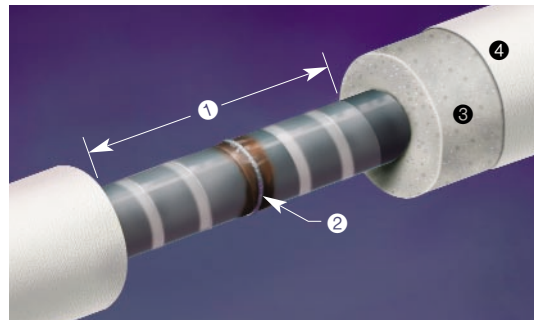

- ❶ **FluoroGrip** high temperature, pressure sensitive, adhesive-backed film wrap
- ❷ Weldment
- ❸ Insulation
- ❹ Insulation jacket

## Let us demonstrate the advantages of FluoroGrip

Contact Integument Technologies for the name of the representative nearest you to arrange a demonstration of FluoroGrip Pipe Wrap.

Disclaimer The information printed herein is furnished free of charge and is based on technical data that Integument Technologies, Inc. believes to be reliable. It is intended for use by persons having technical skill, at their own discretion and risk. The handling precaution information contained herein is given with the understanding that those using it will satisfy themselves that their particular use conditions present no health or safety hazards. While the information contained herein is believed to be correct, Integument Technologies, Inc. makes no representation as to the accuracy of it. Since the conditions of product use are beyond our control, Integument Technologies, Inc. assumes no liability in connection with any use of this information. The evaluation of the product described herein under end-use conditions prior to specifications is essential. Nothing contained herein is to be taken as a license to operate under or as a recommendation to infringe any patents.

**Integument**

*Integument Technologies, Inc.*

70 Pearce Avenue, Tonawanda, NY 14150  
Phone: (716) 873-1199 • Fax: (716) 873-1303  
e-mail: [info@integument.com](mailto:info@integument.com)

[www.integument.com](http://www.integument.com)